



POELSAN®



POELSAN®

ÜRÜN KATALOĞU
PRODUCTION CATALOGUE

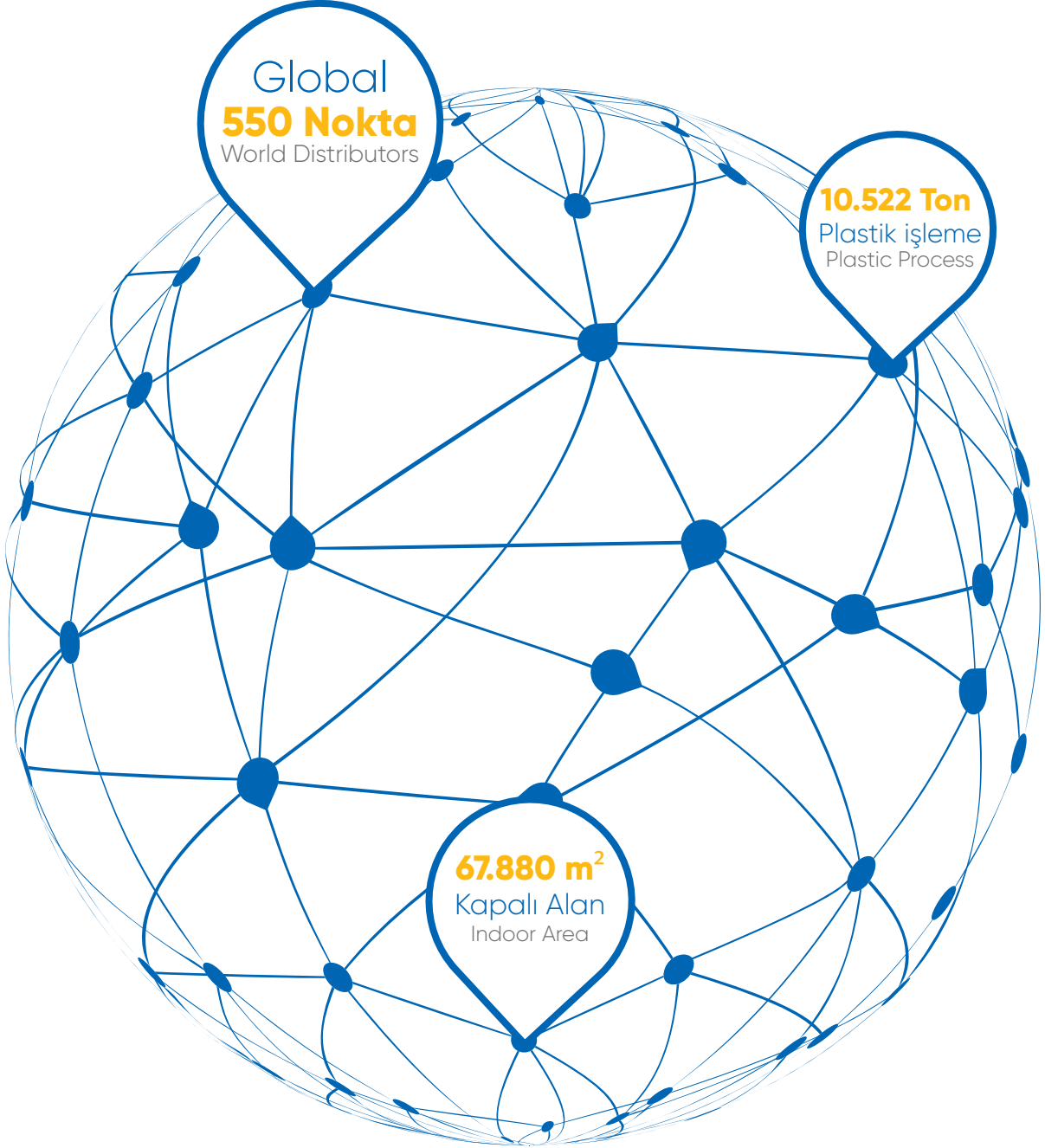

Poelsan Dünya Firmalarıyla Rekabet Ediyor...

+ Poelsan, 1994 yılında henüz ülkemizde üretimi yapılmadığı için ithal edilen Polietilen Kangal Boru Bağlantı Adaptörlerini, kendi tesisinde üreterek piyasaya sunan ilk firma olmuştur.

Poelsan ürünleri, başta peyzaj sektörü olmak üzere, içme suyu şebekelerinde, tarım alanlarında, seralarda, damla sulama sistemlerinde güvenle kullanılabilir. Poelsan ürünleri, başta peyzaj sektörü olmak üzere, içme suyu şebekelerinde, tarım alanlarında, seralarda, damla sulama sistemlerinde güvenle kullanılabilir.

Poelsan, 67.880 m² alanda yıllık 10.522 ton plastik işleme kapasitesiyle üretim yapmaktadır. Poelsan, yurt içinde tüm illere yayılmış yaklaşık 400 bayi ile çalışmakta ve 75 ülkeye ihracat yapmaktadır.

Poelsan, 2.000'in üzerinde ürün çeşidine sahiptir ve sektördeki yeniliklere bağlı olarak mevcut ürün çeşidini sürekli olarak arttırmayı ve sektöründe bir dünya markası olmayı hedeflemektedir.

Poelsan is in the Global Market...

+ Poelsan is the first company that produced and marketed the Compression Fittings for PE Roll Pipes at its own plant, as the mentioned products could not be produced in the country and consequently been imported up to the year 1994.

POELSAN products can be used safely in the areas of landscaping, potable water networks, agricultural irrigation, drip irrigation and greenhouses.

Poelsan produces in 67.880 m² area with its annual plastic process of 10.522 tones. Poelsan cooperates with 400 domestic distributors overall provinces in Turkey and also exports to 75 countries.

Poelsan has a wide product range consisting of more than 2.000 items and aims to extend its current product range consistently depending on the developments in the sector and to be a global brand.



Misyonumuz

- + Teknolojiyi kullanarak yüksek kaliteli ve inovatif ürünler sunmak; bu ürünleri global pazar müşterileri ile buluşturmak.

Vizyonumuz

- + Su sistemlerinde Dünya'da tanınan bir marka ve Türkiye sanayisinin öncü şirketlerinden birisi olmak.

Değerlerimiz

- + İnsan ve Çevreye Saygı
- + Liderlik
- + Güvenilirlik
- + Değerli Hissettirmek
- + Gelişime ve Yeniliğe Açık
- + Takım Ruhu

Our Mission

- + To offer high quality and innovative products using technology; to bring these products together with the global market customers.

Our Vision

- + To become a well known world brand in the World in water systems and one of the leading companies in the Turkish industry.

Our Values

- + Respect for Human and Environment
- + Leadership
- + Reliability
- + Making Feel Valuable
- + Open to Development and Innovation
- + Team Spirit



SEKTÖRÜNDE DÜNYA MARKASI

WORLD'S LEADING BRAND IN THE INDUSTRY



75 2.000 Üzerinde **Ürün Çeşidi**
ÜLKEYE İHRACAT

More than 2.000 products range
exported to 75 countries

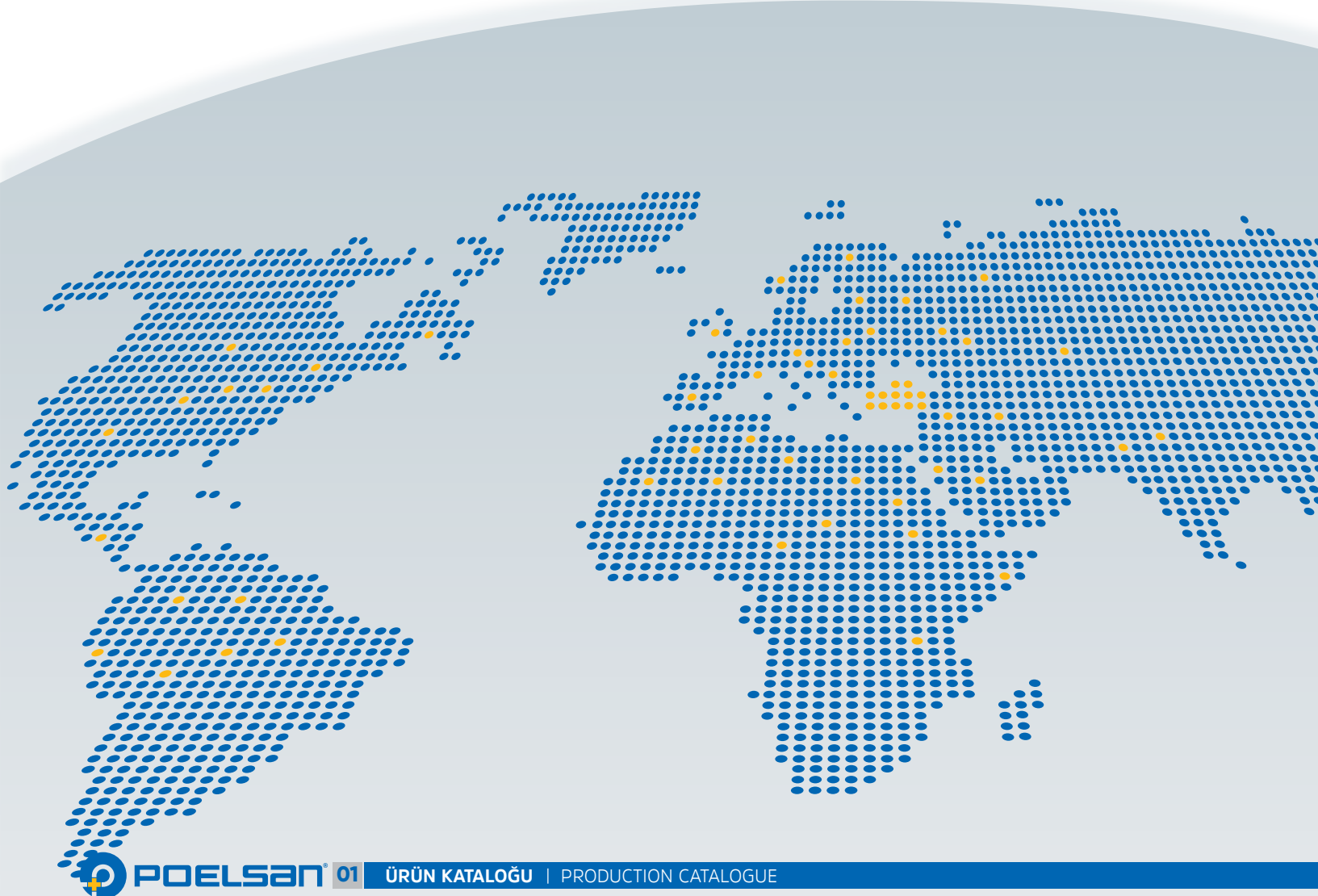

A.B.D. + ALMANYA + ARJANTİN + ARNAVUTLUK + AVUSTRALYA + AZERBAJCAN + BELARUS
BREZİLYA + BİRLEŞİK ARAP EMİRLİKLERİ + BOLİVYA + BOSNA HERSEK + BULGARİSTAN
CEZAYİR + ÇEK CUMHURİYETİ + EKVADOR + ENDONEZYA + ERMENİSTAN + ETİYOPYA
FAS + FRANSA + GÜRCİSTAN + HİNDİSTAN + HOLLANDA + IRAK + İNGİLTERE + İRAN
İRLANDA + İSPANYA + İSRAİL + İTALYA + KAMBOÇYA + KARADAĞ + KATAR + KAZAKİSTAN
KIRGIZİSTAN + KOSOVA + KOSTA RİKA + K.K.T.C. + KUVEYT + LİBYA + LİTVANYA + LÜBNAN
MAKEDONYA + MACARİSTAN + MISIR + MOLDOVA + NORVEÇ + ÖZBEKİSTAN + PAKİSTAN + PERU
POLONYA + PORTEKİZ + ROMANYA + RUSYA + SİRBİSTAN + SLOVAKYA + SURİYE
SUUDİ ARABİSTAN + ŞİLİ + TAYLAND + TUNUS + TÜRKMENİSTAN + UKRAYNA + UMMAN
URUGUAY + ÜRDÜN + YEMEN + VENEZUELA + YENİ ZELANDA + YUNANİSTAN
UNITED STATES OF AMERICA + GERMANY + ARGENTINA + ALBANIA + AUSTRALIA
AZERBAIJAN + BELARUS + BRASIL + UNITED ARAB EMIRATES + BOLIVIA
BOSNIA AND HERZEGOVINA + BULGARIA + ALGERIA + CZECH REPUBLIC + ECUADOR
INDONESIA + ARMENIA + ETHIOPIA + MOROCCO + FRANCE + GEORGIA + INDIA
NETHERLANDS + IRAQ + UNITED KINGDOM + IRAN + IRELAND + SPAIN + ISRAEL + ITALY
CAMBODIA + MONTENEGRO + QATAR + KAZAKHSTAN + KYRGYZSTAN + KOSOVO
COSTA RICA + T.R.N.C + KUWAIT + LIBYA + LITHUANIA + LEBANON
HUNGARY + MACEDONIA + EGYPT + MOLDOVA + NORWAY
UZBEKISTAN + PAKISTAN + PERU + POLAND
PORTUGAL + ROMANIA + RUSSIA + SERBIA
SLOVAKIA + SYRIA + SAUDI ARABIA
CHILE + THAILAND + TUNISIA
TURKMENISTAN + UKRAINE
OMAN + URUGUAY + JORDAN
VENEZUELA + YEMEN
NEW ZEALAND
GREECE

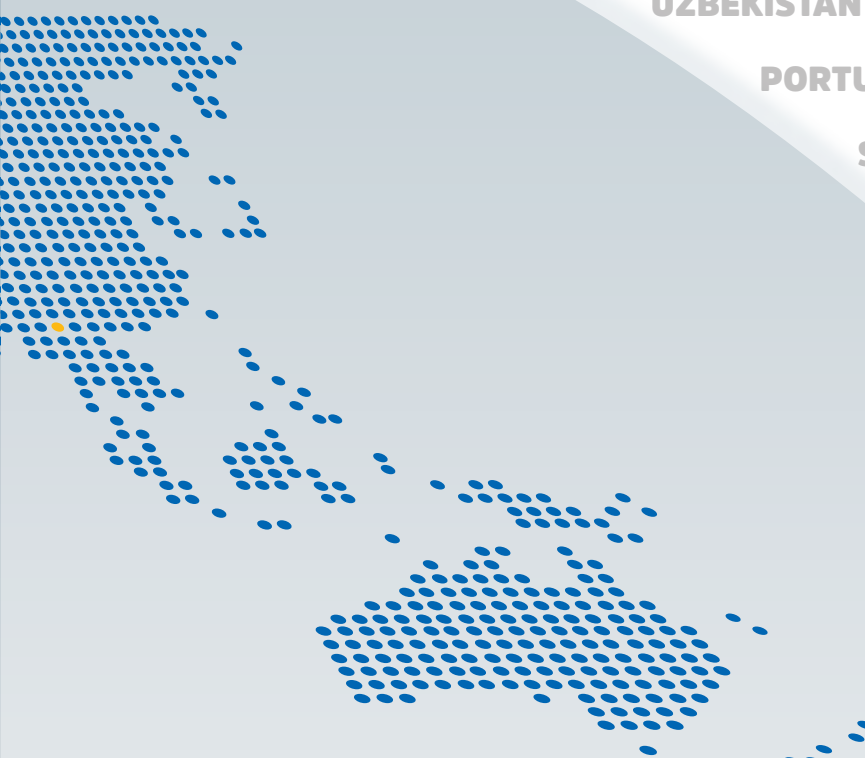

PRİZ KOLYE
CLAMP SADDLES
СЕДЛОВЫЕ ВРЕЗКИ
ربط السرجي

Özellikler

- + Darbelere karşı dayanıklı, yüksek kaliteli polipropilen hammaddeden üretilmiştir.
- + Borulardaki ölçü farklılıklarından doğabilecek sızıntıları önleyebilecek şekilde tasarlanmıştır.
- + Oringi kauçuktan üretilmekte olup yüksek basınç altında sızdırmazlık sağlar.
- + Ürünlerimizde kullanılan korozyona dayanıklı metal yüzük sayesinde 50 °C'yi aşmayan sistemlerde güvenle kullanılabilir.
- + Suyun kokusunu ve tadını değiştirebilecek zararlı bileşikler içermez.
- + İçme suyunda kullanıma uygundur.
- + Metal yüzük, cıvata, somun ve pullar paslanmaz çelik ve galvaniz olarak çeşitlendirilmiştir.
- + Somunlar, alt kapaktaki yuvalarına yerleştirildiği için hızlı ve kolay montaj yapılmasını sağlar.
- + Diş ölçüleri ISO 7-1 Standardına uygundur.
- + ISO 13460-1 Standardına uygundur.

KULLANIM ALANLARI

- + Şehir Şebekesi İçme Suyu
- + Peyzaj Sektörü
- + Tarımsal Sulama
- + Seralar

INSTALLATION AREAS

- + Urban Potable Water Networks
- + Landscaping Systems
- + Agricultural Irrigation
- + Greenhouses

GARANTİ VERİLEN BASINÇ DEĞERLERİ

GUARANTEED PRESSURE VALUES

Ø 25 mm - Ø 110 mm	: PN 16
2"	: PN 10
Ø 125 mm - Ø 225 mm	: PN 10
3" - 4"	: PN 6

Specifications

- + It has been produced from high quality polypropylene raw material and it has resistance to impact.
- + It is designed to prevent leakage caused by the size differences of the pipes.
- + O-rings are made of rubber and provide leakproofness under high pressure.
- + Thanks to the corrosion resistant metal ring used in our products, it can be used safely in systems not exceeding 50 °C.
- + It does not contain any harmful compounds which can change the taste or the smell of the water.
- + It is suitable to be used for drinking water.
- + Reinforcing ring, bolt, nut and washers are varied as stainless steel and galvanized.
- + Because the nuts are inserted in their housing on the lower part, it provides quick and easy installation.
- + Thread sizes are compatible with ISO 7-1 Standard.
- + It is compatible with ISO 13460-1 Standard.



TS ISO 13460-1



PRİZ KOLYE /CLAMP SADDLES

رَبط السرجي / СЕДЛОВЫЕ ВРЕЗКИ



PRİZ KOLYE GALVANİZ CIVATALI & METAL YÜZÜKLÜ

CLAMP SADDLE
WITH GALVANIZED
BOLT & REINFORCING RING

СЕДЛОВАЯ ВРЕЗКА
С УСИЛИВАЮЩИМ
КОЛЬЦОМ

رَبط السرجي مع البراغي
الكلفنايز و الحلقة المدعمة

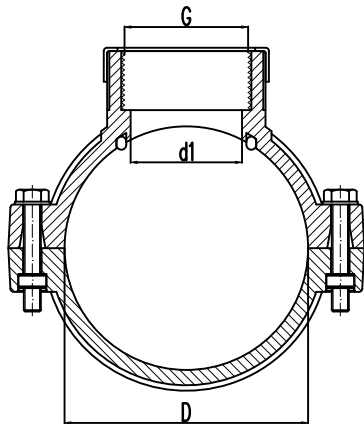

KOD CODE	EBAT / SIZE D x G	CIVATA ADEDİ BOLT QUANTITY	AMBALAJ ADEDİ PACKING QUANTITY	KOLİ ADEDİ BOX QUANTITY	ÇUVAL ADEDİ SACK QUANTITY
100120201	25 x ½"	2	25	300	350
100120301	32 x ½"	2	25	250	300
100120302	32 x ¾"	2	25	250	275
100120401	40 x ½"	2	25	200	200
100120402	40 x ¾"	2	25	175	200
100120501	50 x ½"	2	10	160	180
100120502	50 x ¾"	2	10	150	180
100120503	50 x 1"	2	10	130	150
100120601	63 x ½"	4	10	110	120
100120602	63 x ¾"	4	10	110	120
100120603	63 x 1"	4	10	100	110
100120604	63 x 1¼"	4	10	80	90
100120605	63 x 1½"	4	10	80	90
100120701	75 x ½"	4	5	90	110
100120702	75 x ¾"	4	5	90	110
100120703	75 x 1"	4	5	80	90
100120704	75 x 1¼"	4	5	55	60
100120705	75 x 1½"	4	5	55	70
100120706	75 x 2"	4	5	50	60
100120801	90 x ½"	4	5	75	85
100120802	90 x ¾"	4	5	70	80
100120803	90 x 1"	4	5	60	70
100120804	90 x 1¼"	4	5	40	50
100120805	90 x 1½"	4	5	40	50
100120806	90 x 2"	4	5	40	50
100120901	110 x ½"	4	5	55	65
100120902	110 x ¾"	4	5	55	65
100120903	110 x 1"	4	5	50	60
100120904	110 x 1¼"	4	5	35	40
100120905	110 x 1½"	4	5	35	45
100120906	110 x 2"	4	5	30	35
100121001	125 x ½"	4	2	44	40
100121002	125 x ¾"	4	2	44	40
100121003	125 x 1"	4	2	40	40
100121004	125 x 1¼"	4	2	40	40
100121005	125 x 1½"	4	2	42	40
100121006	125 x 2"	4	2	42	40
100121101	140 x ½"	6	2	36	36

KOD CODE	EBAT / SIZE D x G	CIVATA ADEDİ BOLT QUANTITY	AMBALAJ ADEDİ PACKING QUANTITY	KOLİ ADEDİ BOX QUANTITY	ÇUVAL ADEDİ SACK QUANTITY
100121102	140 x ¾"	6	2	36	36
100121103	140 x 1"	6	2	36	36
100121104	140 x 1¼"	6	2	36	36
100121105	140 x 1½"	6	2	40	32
100121106	140 x 2"	6	2	40	32
100121201	160 x ½"	6	2	26	24
100121202	160 x ¾"	6	2	26	24
100121203	160 x 1"	6	2	26	24
100121204	160 x 1¼"	6	2	24	24
100121205	160 x 1½"	6	2	24	24
100121206	160 x 2"	6	2	22	24
100121207	160 x 2½"	6	2	16	14
100121208	160 x 3"	6	2	12	12
100121209	160 x 4"	6	2	12	12
100121302	180 x ¾"	6	2	10	14
100121303	180 x 1"	6	2	10	14
100121304	180 x 1¼"	6	2	10	14
100121305	180 x 1½"	6	2	10	14
100121306	180 x 2"	6	2	10	14
100121307	180 x 2½"	6	2	10	12
100121308	180 x 3"	6	2	10	12
100121309	180 x 4"	6	2	8	10
100121402	200 x ¾"	6	2	10	12
100121403	200 x 1"	6	2	10	12
100121404	200 x 1¼"	6	2	10	12
100121405	200 x 1½"	6	2	10	12
100121406	200 x 2"	6	2	8	8
100121407	200 x 2½"	6	2	8	8
100121408	200 x 3"	6	2	8	8
100121409	200 x 4"	6	2	8	8
100121503	225 x 1"	6	2	8	8
100121504	225 x 1¼"	6	2	8	8
100121505	225 x 1½"	6	2	8	8
100121506	225 x 2"	6	2	8	8
100121507	225 x 2½"	6	2	8	8
100121508	225 x 3"	6	2	8	8
100121509	225 x 4"	6	2	8	8



PRİZ KOLYE GALVANİZ CIVATALI & METAL YÜZÜKLÜ

CLAMP SADDLE
WITH GALVANIZED
BOLT & REINFORCING RING

СЕДЛОВАЯ ВРЕЗКА
С УСИЛИВАЮЩИМ
КОЛЬЦОМ

ربط السرجي مع البراغي
الكفنايز و الحلقة المدعمة

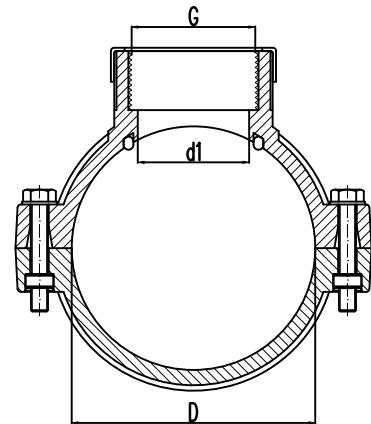

ربط السرجي / СЕДЛОВАЯ ВРЕЗКА

PRİZ KOLYE / CLAMP SADDLES

ربط السرجي / СЕДЛОВЫЕ ВРЕЗКИ



PRİZ KOLYE ÇİFT ÇIKIŞLI GALVANİZ CIVATALI & METAL YÜZÜKLÜ

DOUBLE ENDED CLAMP SADDLE
WITH GALVANIZED
BOLT & REINFORCING RING

ДВУХСТОРОННЯЯ
СЕДЛОВАЯ ВРЕЗКА С
УСИЛИВАЮЩИМ КОЛЬЦОМ

ربط السرجي مع البراغي

الكفنايز و الحلقة المدعمة المزدوجة

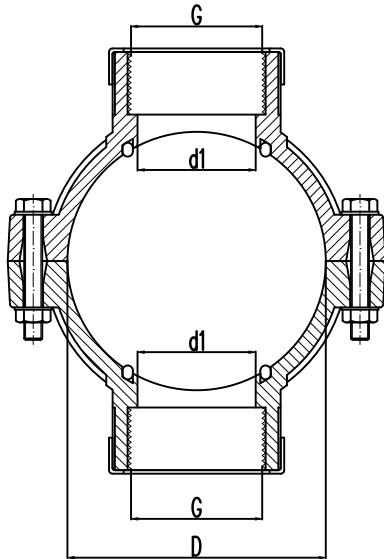

KOD CODE	EBAT / SIZE D x G	CIVATA ADEDİ BOLT QUANTITY	AMBALAJ ADEDİ PACKING QUANTITY	KOLİ ADEDİ BOX QUANTITY	ÇUVAL ADEDİ SACK QUANTITY
100140201	25 x 1/2" x 1/2"	2	25	250	275
100140301	32 x 1/2" x 1/2"	2	25	200	250
100140302	32 x 3/4" x 3/4"	2	25	200	250
100140401	40 x 1/2" x 1/2"	2	25	150	180
100140402	40 x 3/4" x 3/4"	2	25	150	180
100140501	50 x 1/2" x 1/2"	2	10	140	170
100140502	50 x 3/4" x 3/4"	2	10	120	160
100140503	50 x 1" x 1"	2	10	120	130
100140601	63 x 1/2" x 1/2"	4	10	90	110
100140602	63 x 3/4" x 3/4"	4	10	90	100
100140603	63 x 1" x 1"	4	10	80	90
100140604	63 x 1 1/4" x 1 1/4"	4	10	50	60
100140605	63 x 1 1/2" x 1 1/2"	4	10	50	60
100140701	75 x 1/2" x 1/2"	4	5	80	90
100140702	75 x 3/4" x 3/4"	4	5	80	90
100140703	75 x 1" x 1"	4	5	70	80
100140704	75 x 1 1/4" x 1 1/4"	4	5	40	45
100140705	75 x 1 1/2" x 1 1/2"	4	5	40	45
100140706	75 x 2" x 2"	4	5	40	45
100140801	90 x 1/2" x 1/2"	4	5	60	80
100140802	90 x 3/4" x 3/4"	4	5	60	80
100140803	90 x 1" x 1"	4	5	50	60
100140804	90 x 1 1/4" x 1 1/4"	4	5	35	40
100140805	90 x 1 1/2" x 1 1/2"	4	5	35	40
100140806	90 x 2" x 2"	4	5	30	40
100140901	110 x 1/2" x 1/2"	4	5	50	65
100140902	110 x 3/4" x 3/4"	4	5	50	65
100140903	110 x 1" x 1"	4	5	40	50
100140904	110 x 1 1/4" x 1 1/4"	4	5	30	35
100140905	110 x 1 1/2" x 1 1/2"	4	5	30	35
100140906	110 x 2" x 2"	4	5	30	35
100141001	125 x 1/2" x 1/2"	4	2	50	48
100141002	125 x 3/4" x 3/4"	4	2	48	48
100141003	125 x 1" x 1"	4	2	42	40
100141004	125 x 1 1/4" x 1 1/4"	4	2	42	40
100141005	125 x 1 1/2" x 1 1/2"	4	2	36	40
100141006	125 x 2" x 2"	4	2	34	34
100141101	140 x 1/2" x 1/2"	6	2	36	36

KOD CODE	EBAT / SIZE D x G	CIVATA ADEDİ BOLT QUANTITY	AMBALAJ ADEDİ PACKING QUANTITY	KOLİ ADEDİ BOX QUANTITY	ÇUVAL ADEDİ SACK QUANTITY
100141102	140 x ¾" x ¾"	6	2	34	36
100141103	140 x 1" x 1"	6	2	28	34
100141104	140 x 1¼" x 1¼"	6	2	26	28
100141105	140 x 1½" x 1½"	6	2	22	28
100141106	140 x 2" x 2"	6	2	22	28
100141201	160 x ½" x ½"	6	2	26	28
100141202	160 x ¾" x ¾"	6	2	26	28
100141203	160 x 1" x 1"	6	2	24	28
100141204	160 x 1¼" x 1¼"	6	2	22	24
100141205	160 x 1½" x 1½"	6	2	20	24
100141206	160 x 2" x 2"	6	2	20	24
100141207	160 x 2½" x 2½"	6	2	12	14
100141208	160 x 3" x 3"	6	2	12	12
100141209	160 x 4" x 4"	6	2	10	10
100141302	180 x ¾" x ¾"	6	2	10	14
100141303	180 x 1" x 1"	6	2	10	14
100141304	180 x 1¼" x 1¼"	6	2	10	14
100141305	180 x 1½" x 1½"	6	2	10	14
100141306	180 x 2" x 2"	6	2	10	14
100141307	180 x 2½" x 2½"	6	2	8	10
100141308	180 x 3" x 3"	6	2	8	10
100141309	180 x 4" x 4"	6	2	6	8
100141402	200 x ¾" x ¾"	6	2	10	12
100141403	200 x 1" x 1"	6	2	10	12
100141404	200 x 1¼" x 1¼"	6	2	10	10
100141405	200 x 1½" x 1½"	6	2	8	10
100141406	200 x 2" x 2"	6	2	8	10
100141407	200 x 2½" x 2½"	6	2	8	10
100141408	200 x 3" x 3"	6	2	8	8
100141409	200 x 4" x 4"	6	2	6	8
100141503	225 x 1" x 1"	6	2	8	8
100141504	225 x 1¼" x 1¼"	6	2	8	8
100141505	225 x 1½" x 1½"	6	2	8	8
100141506	225 x 2" x 2"	6	2	8	8
100141507	225 x 2½" x 2½"	6	2	8	8
100141508	225 x 3" x 3"	6	2	8	8
100141509	225 x 4" x 4"	6	2	4	8



ربط السرجي /
СЕДЛОВЫЕ ВРЕЗКИ

PRİZ KOLYE ÇİFT ÇIKIŞLI GALVANİZ CIVATALI & METAL YÜZÜKLÜ

DOUBLE ENDED CLAMP SADDLE
WITH GALVANIZED
BOLT & REINFORCING RING

ДВУХСТОРОННЯЯ
СЕДЛОВАЯ ВРЕЗКА С
УСИЛИВАЮЩИМ КОЛЬЦОМ

ربط السرجي مع البراغي
الكفنايز و الحلقة المدعمة المزدوجة

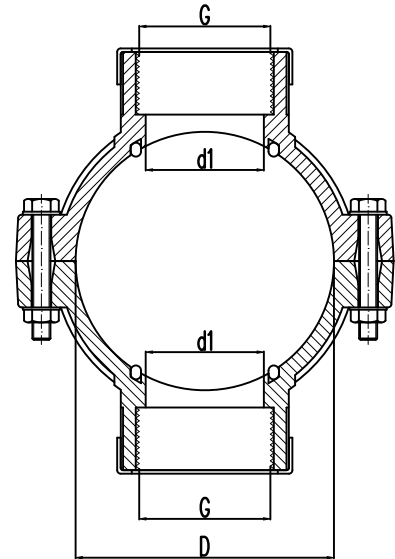



**PRİZ KOLYE
PASLANMAZ CIVATALI
(AISI304)
PASLANMAZ METAL YÜZÜKLÜ
(AISI430)**

CLAMP SADDLE
WITH STAINLESS STEEL BOLT
(AISI304)
STAINLESS STEEL REINFORCING RING
(AISI430)

СЕДЛОВАЯ ВРЕЗКА
С УСИЛИВАЮЩИМ
КОЛЬЦОМ ИЗ
НЕРЖАВЕЮЩЕЙ СТАЛИ

ربط السرجي مع البراغي
الفولاذ و الحلقة المدعمة

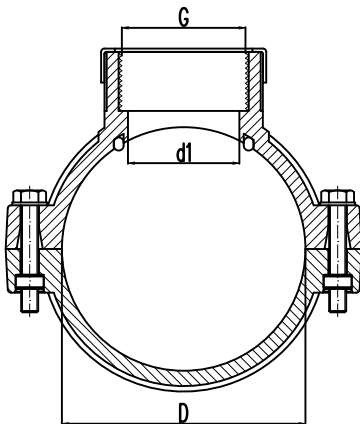

KOD CODE	EBAT / SIZE D x G	CIVATA ADEDİ BOLT QUANTITY	AMBALAJ ADEDİ PACKING QUANTITY	KOLİ ADEDİ BOX QUANTITY	ÇUVAL ADEDİ SACK QUANTITY
100160201	25 x ½"	2	25	300	350
100160301	32 x ½"	2	25	250	300
100160302	32 x ¾"	2	25	250	275
100160401	40 x ½"	2	25	200	200
100160402	40 x ¾"	2	25	175	200
100160501	50 x ½"	2	10	160	180
100160502	50 x ¾"	2	10	150	180
100160503	50 x 1"	2	10	130	150
100160601	63 x ½"	4	10	110	120
100160602	63 x ¾"	4	10	110	120
100160603	63 x 1"	4	10	100	110
100160604	63 x 1¼"	4	10	80	90
100160605	63 x 1½"	4	10	80	90
100160701	75 x ½"	4	5	90	110
100160702	75 x ¾"	4	5	90	110
100160703	75 x 1"	4	5	80	90
100160704	75 x 1¼"	4	5	55	60
100160705	75 x 1½"	4	5	50	60
100160706	75 x 2"	4	5	50	60
100160801	90 x ½"	4	5	75	85
100160802	90 x ¾"	4	5	70	80
100160803	90 x 1"	4	5	60	70
100160804	90 x 1¼"	4	5	40	50
100160805	90 x 1½"	4	5	40	50
100160806	90 x 2"	4	5	40	50
100160901	110 x ½"	4	5	55	65
100160902	110 x ¾"	4	5	55	65
100160903	110 x 1"	4	5	50	60
100160904	110 x 1¼"	4	5	35	40
100160905	110 x 1½"	4	5	35	45
100160906	110 x 2"	4	5	30	35
100161001	125 x ½"	4	2	44	40
100161002	125 x ¾"	4	2	44	40
100161003	125 x 1"	4	2	40	40
100161004	125 x 1¼"	4	2	40	40
100161005	125 x 1½"	4	2	40	40
100161006	125 x 2"	4	2	40	40
100161101	140 x ½"	6	2	36	36

KOD CODE	EBAT / SIZE D x G	CIVATA ADEDİ BOLT QUANTITY	AMBALAJ ADEDİ PACKING QUANTITY	KOLİ ADEDİ BOX QUANTITY	ÇUVAL ADEDİ SACK QUANTITY
100161102	140 x ¾"	6	2	36	36
100161103	140 x 1"	6	2	36	36
100161104	140 x 1¼"	6	2	36	36
100161105	140 x 1½"	6	2	36	32
100161106	140 x 2"	6	2	28	32
100161201	160 x ½"	6	2	26	24
100161202	160 x ¾"	6	2	26	24
100161203	160 x 1"	6	2	26	24
100161204	160 x 1¼"	6	2	24	24
100161205	160 x 1½"	6	2	24	24
100161206	160 x 2"	6	2	22	24
100161207	160 x 2½"	6	2	16	14
100161208	160 x 3"	6	2	12	12
100161209	160 x 4"	6	2	12	12
100161302	180 x ¾"	6	2	10	14
100161303	180 x 1"	6	2	10	14
100161304	180 x 1¼"	6	2	10	14
100161305	180 x 1½"	6	2	10	14
100161306	180 x 2"	6	2	10	14
100161307	180 x 2½"	6	2	10	12
100161308	180 x 3"	6	2	10	12
100161309	180 x 4"	6	2	8	10
100161402	200 x ¾"	6	2	10	12
100161403	200 x 1"	6	2	10	12
100161404	200 x 1¼"	6	2	10	12
100161405	200 x 1½"	6	2	10	12
100161406	200 x 2"	6	2	8	8
100161407	200 x 2½"	6	2	8	8
100161408	200 x 3"	6	2	8	8
100161409	200 x 4"	6	2	8	8
100161503	225 x 1"	6	2	8	8
100161504	225 x 1¼"	6	2	8	8
100161505	225 x 1½"	6	2	8	8
100161506	225 x 2"	6	2	8	8
100161507	225 x 2½"	6	2	8	8
100161508	225 x 3"	6	2	8	8
100161509	225 x 4"	6	2	8	8



**PRİZ KOLYE
PASLANMAZ CIVATALI
(AISI304)
PASLANMAZ METAL YÜZÜKLÜ
(AISI430)**

CLAMP SADDLE
WITH STAINLESS STEEL BOLT
(AISI304)
STAINLESS STEEL REINFORCING RING
(AISI430)

СЕДЛОВАЯ ВРЕЗКА
С УСИЛИВАЮЩИМ
КОЛЬЦОМ ИЗ
НЕРЖАВЕЮЩЕЙ СТАЛИ

ربط السرجي مع البراغي
الفولاذ والحلقة المدعمة

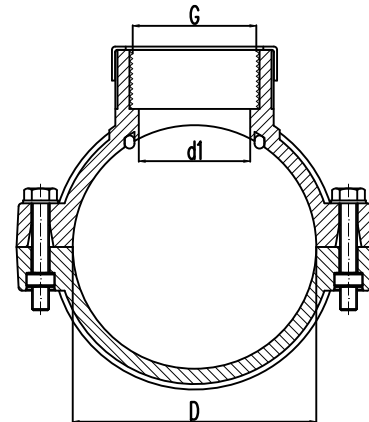

ربط السرجي مع البراغي الكلفنايز و الحلقة المدعمة المزودة ب AISI 304 / 304 AISI НЕРЖАВЕЮЩЕЙ СТАЛИ ИЗ НЕРЖАВЕЮЩИМ КОЛЬЦОМ ИЗ НЕРЖАВЕЮЩЕЙ СТАЛИ



**PRİZ KOLYE ÇİFT ÇIKIŞLI
PASLANMAZ CIVATALI
(AISI304)
PASLANMAZ METAL YÜZÜKLÜ
(AISI430)**

DOUBLE ENDED CLAMP SADDLE
WITH STAINLESS STEEL BOLT
(AISI304)
STAINLESS STEEL
REINFORCING RING
(AISI430)

ДВУХСТОРОННЯЯ СЕДЛОВАЯ
ВРЕЗКА С УСИЛИВАЮЩИМ КОЛЬЦОМ
ИЗ НЕРЖАВЕЮЩЕЙ СТАЛИ
ربط السرجي مع البراغي الفولاذ و
الحلقة المدعمة المزودة

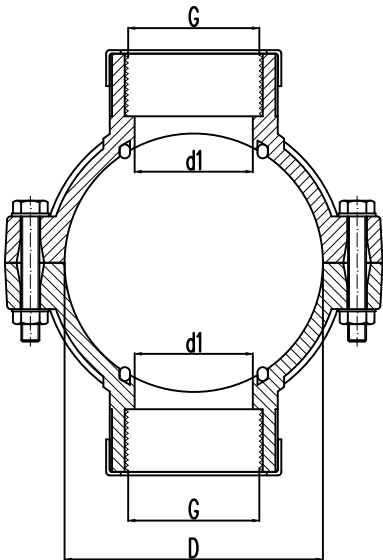

KOD CODE	EBAT / SIZE D x G	CIVATA ADEDİ BOLT QUANTITY	AMBALAJ ADEDİ PACKING QUANTITY	KOLİ ADEDİ BOX QUANTITY	ÇİVAL ADEDİ SACK QUANTITY
100180201	25 x 1/2" x 1/2"	2	25	250	275
100180301	32 x 1/2" x 1/2"	2	25	200	250
100180302	32 x 3/4" x 3/4"	2	25	200	250
100180401	40 x 1/2" x 1/2"	2	25	150	180
100180402	40 x 3/4" x 3/4"	2	25	150	180
100180501	50 x 1/2" x 1/2"	2	10	140	170
100180502	50 x 3/4" x 3/4"	2	10	120	160
100180503	50 x 1" x 1"	2	10	120	130
100180601	63 x 1/2" x 1/2"	4	10	90	110
100180602	63 x 3/4" x 3/4"	4	10	90	100
100180603	63 x 1" x 1"	4	10	80	90
100180604	63 x 1 1/4" x 1 1/4"	4	10	50	60
100180605	63 x 1 1/2" x 1 1/2"	4	10	50	60
100180701	75 x 1/2" x 1/2"	4	5	80	90
100180702	75 x 3/4" x 3/4"	4	5	80	90
100180703	75 x 1" x 1"	4	5	70	80
100180704	75 x 1 1/4" x 1 1/4"	4	5	40	45
100180705	75 x 1 1/2" x 1 1/2"	4	5	40	45
100180706	75 x 2" x 2"	4	5	40	45
100180801	90 x 1/2" x 1/2"	4	5	60	80
100180802	90 x 3/4" x 3/4"	4	5	60	80
100180803	90 x 1" x 1"	4	5	50	60
100180804	90 x 1 1/4" x 1 1/4"	4	5	35	40
100180805	90 x 1 1/2" x 1 1/2"	4	5	35	40
100180806	90 x 2" x 2"	4	5	50	65
100180901	110 x 1/2" x 1/2"	4	5	50	65
100180902	110 x 3/4" x 3/4"	4	5	40	50
100180903	110 x 1" x 1"	4	5	30	35
100180904	110 x 1 1/4" x 1 1/4"	4	5	35	40
100180905	110 x 1 1/2" x 1 1/2"	4	5	30	35
100180906	110 x 2" x 2"	4	5	30	35
100181001	125 x 1/2" x 1/2"	4	2	50	48
100181002	125 x 3/4" x 3/4"	4	2	48	48
100181003	125 x 1" x 1"	4	2	42	40
100181004	125 x 1 1/4" x 1 1/4"	4	2	42	40
100181005	125 x 1 1/2" x 1 1/2"	4	2	36	40
100181006	125 x 2" x 2"	4	2	34	34
100181101	140 x 1/2" x 1/2"	6	2	36	36

KOD CODE	EBAT / SIZE D x G	CIVATA ADEDİ BOLT QUANTITY	AMBALAJ ADEDİ PACKING QUANTITY	KOLİ ADEDİ BOX QUANTITY	ÇUVAL ADEDİ SACK QUANTITY
100181102	140 x ¾" x ¾"	6	2	34	36
100181103	140 x 1" x 1"	6	2	28	34
100181104	140 x 1¼" x 1¼"	6	2	26	28
100181105	140 x 1½" x 1½"	6	2	22	28
100181106	140 x 2" x 2"	6	2	22	28
100181201	160 x ½" x ½"	6	2	26	26
100181202	160 x ¾" x ¾"	6	2	26	28
100181203	160 x 1" x 1"	6	2	24	28
100181204	160 x 1¼" x 1¼"	6	2	22	24
100181205	160 x 1½" x 1½"	6	2	20	24
100181206	160 x 2" x 2"	6	2	20	24
100181207	160 x 2½" x 2½"	6	2	12	14
100181208	160 x 3" x 3"	6	2	12	12
100181209	160 x 4" x 4"	6	2	10	10
100181302	180 x ¾" x ¾"	6	2	10	14
100181303	180 x 1" x 1"	6	2	10	14
100181304	180 x 1¼" x 1¼"	6	2	10	14
100181305	180 x 1½" x 1½"	6	2	10	14
100181306	180 x 2" x 2"	6	2	10	14
100181307	180 x 2½" x 2½"	6	2	8	10
100181308	180 x 3" x 3"	6	2	8	10
100181309	180 x 4" x 4"	6	2	6	8
100181402	200 x ¾" x ¾"	6	2	10	12
100181403	200 x 1" x 1"	6	2	10	12
100181404	200 x 1¼" x 1¼"	6	2	10	10
100181405	200 x 1½" x 1½"	6	2	8	10
100181406	200 x 2" x 2"	6	2	8	10
100181407	200 x 2½" x 2½"	6	2	8	10
100181408	200 x 3" x 3"	6	2	8	8
100181409	200 x 4" x 4"	6	2	6	8
100181503	225 x 1" x 1"	6	2	8	8
100181504	225 x 1¼" x 1¼"	6	2	8	8
100181505	225 x 1½" x 1½"	6	2	8	8
100181506	225 x 2" x 2"	6	2	8	8
100181507	225 x 2½" x 2½"	6	2	8	8
100181508	225 x 3" x 3"	6	2	8	8
100181509	225 x 4" x 4"	6	2	4	8



**PRİZ KOLYE ÇİFT ÇIKIŞLI
PASLANMAZ CIVATALI
(AISI304)
PASLANMAZ METAL YÜZÜKLÜ
(AISI430)**

DOUBLE ENDED CLAMP SADDLE
WITH STAINLESS STEEL BOLT
(AISI304)

STAINLESS STEEL
REINFORCING RING
(AISI430)

ДВУХСТОРОННЯЯ СЕДЛОВАЯ
ВРЕЗКА С УСИЛИВАЮЩИМ КОЛЬЦОМ
ИЗ НЕРЖАВЕЮЩЕЙ СТАЛИ

ربط السرجي مع البراغي الفولاذ و
الحلقة المدعمة المزدوجة

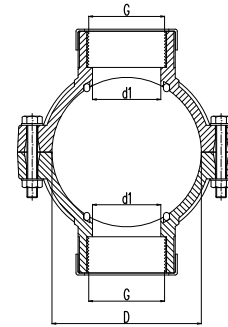

MANYETİK LOKMA UÇ

MAGNETIC SOCKET WRENCH
МАГНИТНЫЙ ТОРЦЕВОЙ КЛЮЧ

مفتاح البراغي المغناطيسية

KOD CODE	EBAT / SIZE	AMBALAJ ADEDİ PACKING QUANTITY
16080	10 mm	5
16083	13 mm	5

PRİZ KOLYELERİN MONTAJ TALİMATI

INSTALLATION INSTRUCTIONS FOR CLAMP SADDLES

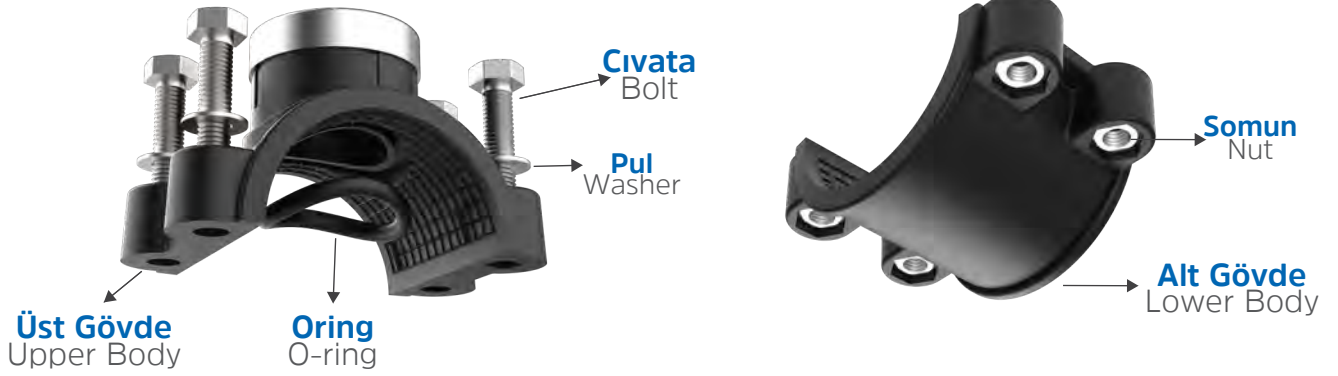

- 1** Borunun çıkış alacağınız noktayı işaretleyiniz.

Mark the point from where you will take off the pipe.



- 2** Priz kolye oringini, üst kapak üzerinde bulunan oring yuvasına düzgün şekilde yerleştiriniz.

Place the O-ring properly into the socket on the upper body.



- 3** Boru üzerinde önce somunları monte edilmiş alt kapağı, sonra üst kapağını boru üzerinde işaretlediğiniz noktaya göre boruya takınız.

First, mount the lower part to the pipe which nuts are inserted on it, then mount the upper part according to the point you marked before on the pipe.



PRİZ KOLYELERİN MONTAJ TALİMATI

INSTALLATION INSTRUCTIONS FOR CLAMP SADDLES

- 4 Cıvata ve pulu, manyetik lokma ucuna takınız. Priz kolyelerin çapına uygun tork değerlerine göre matkabınızı ayarlayınız.

Mount the bolt and the washer into the tip of magnetic socket wrench. Adjust the drill according to the appropriate torque values for clamp saddles dimension.

EBAT / SIZE mm	TORK DEĞERLERİ TORQUE VALUES (nm)
Ø25 - Ø32 - Ø40 - Ø50	4,5 Nm
Ø63 - Ø75 - Ø90 - Ø110	6,3 Nm
Ø125 - Ø140	12 Nm
Ø160 - Ø180	13 Nm
Ø200 - Ø225	14 Nm

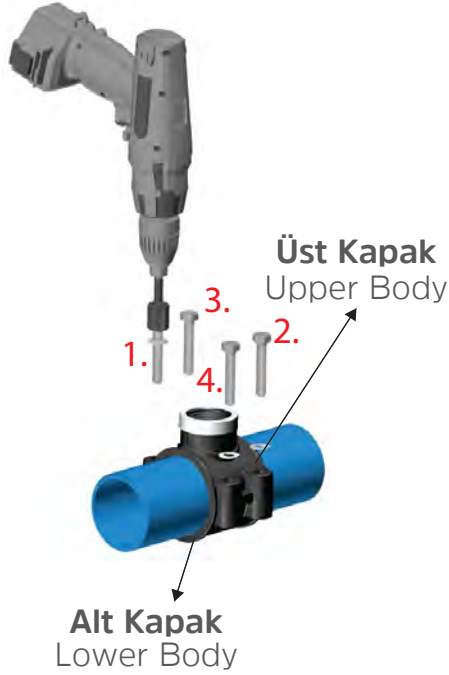
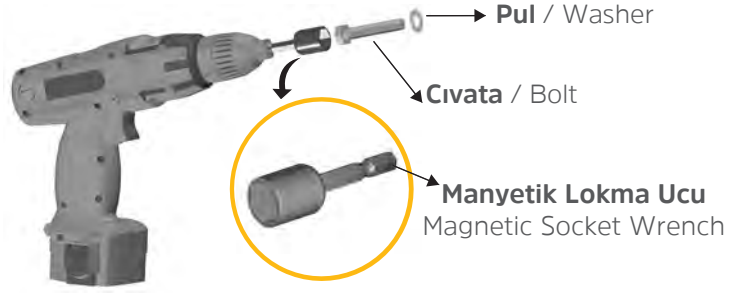

- 5 1. Cıvata ve pulu üst kapak üzerindeki yuvalarına yerleştirerek yarım sıkınız. Sırasıyla, 2. 3. ve 4. cıvataları ve pulları tam sıkınız. Son olarak yarım sıkılan 1. cıvata ve pulu tam sıkınız.

Place the 1st bolt and washer in their housing on the upper part and screw it halfway. Screw completely the 2nd, 3rd and 4th bolts and washers in sequence. Finally completely screw the 1st bolt and washer which are half screwed at the beginning.



- 6 Diş ölçüsüne uygun bir matkap ucu ile ek parçaya değmeyecek şekilde boru delme işlemini gerçekleştiriniz.

Carry out the pipe drilling without touching the saddles with an appropriate drill bit for the thread dimension.

PRİZ KOLYE

CLAMP SADDLES

СЕДЛОВЫЕ ВРЕЗКИ

ربط السرجي

DİKKAT EDİLMESİ GEREKEN HUSUSLAR

- + Priz Kolyeler depolama ve montaj esnasında sert ve keskin cisimlerden uzak tutulmalıdır. Tesisat toprak altına döşenecekse, sert ve keskin cisimlerden korumak amacıyla kum ile kapatılmalıdır. Hasar görmüş ürünler kesinlikle kullanılmamalıdır.
- + Priz kolyelerde oring, yuvasına düzgünce yerleştirilmeli ve montaj esnasında yerinden çıkmamasına özen gösterilmelidir.
- + Priz kolye ile kullanılacak erkek adaptörlere teflon bant sızdırmazlığı sağlayacak kadar ve sıkma yönüyle aynı yönde sarılmalıdır.
- + Priz kolyelerin montajından sonra yapılan boru delme işlemi, uygun bir matkap ucu ile dişlere değmeyecek şekilde gerçekleştirilmelidir.
- + Boruda standart değerinden daha büyük bir ölçüde ise priz kolye montajında alt ve üst kapaklar birbirine değmeyecektir. Bu durumda; cıvatalı priz kolyelerin cıvatalarının alt ve üst kapaklar birbirine değene kadar sıkılmasına gerek yoktur.
- + Priz kolyelerin montajı sırasında cıvata ve somunlar karşılıklı olarak dengeli sıkılmalıdır.

POINTS TO TAKE INTO CONSIDERATION

- + Clamp saddles should be kept away from hard and sharp objects during the storage and installation. If the installation is laid under the ground, it should be covered with sand to protect it from hard and sharp objects. Any damaged adaptor should not be used absolutely.
- + The o-ring should be placed in its socket properly in order not to be unsettled during the installation.
- + Male adaptors to be used with Clamp Saddles, should be wrapped up with the teflon band with the tightening direction and should be wrapped enough to prevent leakage.
- + Drilling the pipe after the installation of Clamp Saddles can cause the damage of the threads. Thus, drilling must be carried out in a way that it does not touch the threads with a suitable drill bit.
- + If the dimension of the installed pipes is bigger than the standard values upper and lower parts will not contact each other. Under these circumstances, there is no need to tighten the bolts till the upper and lower body parts contact or hammer the slides to the end point.
- + Bolts and nuts must be tightened mutually balanced during installation of the Clamp Saddles.

PRİZ KOLYE

CLAMP SADDLES
СЕДЛОВЫЕ ВРЕЗКИ
ربط السرجي

Tesisatın Son Kontrolü

GÖZLE KONTROL

Tesisatın kurulumu sırasında kullanılan ürünlerin hasar tespiti için mutlaka gözle kontrol yapılmalıdır.

SIZDIRMAZLIK KONTROLÜ

Tesisatın kurulumu sonrasında sisteme mutlaka test basıncında su verilmeli ve sızdırmazlık durumu tespit edilmelidir.

SIZINTIYA NEDEN OLABİLECEK UYGULAMALAR

- Boru ölçülerinin uluslararası standartlara uygun olmaması,
- Kullanılan diğer metal ya da plastik malzemenin uluslararası standartlara uygun olmaması,
- Teflon bandın yeterli miktarda ve uygun şekilde kullanılmaması,
- Montaj sırasında Priz Kolyenin talimatlara uygun monte edilmemesi,
- Matkap ile boru delme esnasında Priz kolyenin dişlerine zarar verilmesi,
- Montaj esnasında oringin zarar görmesi ya da oringin yerinden çıkması,

tesisatınızda sızıntıya neden olabilir.

Final Check of the Installation

VISUAL CHECK

During installation, the system should be checked visually in order to determine the damaged clamp saddles.

LEAKPROOFNESS CHECK

After the installation, the system should be checked with water in testing pressure to determine the water leak.

CONDITIONS THAT MAY CAUSE LEAKAGE

- Pipe sizes do not comply with international standards,
- Other metal or plastic materials used do not comply with international standards,
- Not to use the teflon band sufficiently and suitably,
- Incorrect installation of the Clamp Saddles during installation,
- Damage of the threads of the Clamp Saddles during pipe drilling with the drill,
- Damage or displacing of the oring during the installation,

can cause leaking in your installation.

ISO 13460-1 STANDARDI - TESTLER

ISO 13460-1 STANDARD - TESTS



UZUN SÜRELİ İÇ HİDROSTATİK BASINCA DAYANIM TESTİ

Priz Kolyeler, ISO 1167-1 test standardına göre test edilmektedir.

RESISTANCE TO LONG-TERM INTERNAL HYDROSTATIC PRESSURE

Clamp Saddles are tested according to the ISO 1167-1 test standard.

MALZEME MATERIAL	PN PN	TEST SICAKLIĞI / (°C) TEST TEMPERATURE / (°C)	TEST SÜRESİ / (SAAT) TEST DURATION / (HOUR)	TEST BASINCI / (BAR) TEST PRESSURE / (BAR)
PP-H	16 BAR	20 95	1 1.000	42.0 7.0
PP-H	10 BAR	20 95	1 1.000	26.8 4.5
PP-H	6 BAR	20 95	1 1.000	12.8 2.8

* Test Basıncı değerleri, her çap için değişmekte olup, yaklaşık değerlerdir.

* Test pressure values are variable for each dimensions and are approximate values.



İÇ HİDROSTATİK BASINCA DAYANIM TESTİ

RESISTANCE TO SHORT-TERM INTERNAL HYDROSTATIC PRESSURE

PN PN	TEST SICAKLIĞI / (°C) TEST TEMPERATURE / (°C)	TEST SÜRESİ / (SAAT) TEST DURATION / (HOUR)	TEST BASINCI / (BAR) TEST PRESSURE / (BAR)
16 BAR	20	1	24.0
10 BAR	20	1	15.0
6 BAR	20	1	9.0



DAİRESEL KAYMA DİRENCİ TESTİ CIRCULAR SLIP RESISTANCE TEST

RESISTANCE TO PRESSURE DURING APPLICATION OF A BENDING MOMENT (M= 0,4D) TO THE BRANCH OUTLET

TEST SICAKLIĞI / (°C) TEST TEMPERATURE / (°C)	TEST MOMENTİ / (N.m) TEST MOMENT / (N.m)	TEST SÜRESİ / (DAKİKA) TEST DURATION / (MINUTE)
20 ± 3	0.4 x D	1

DİŞLER Priz Kolyeler için dişler, ISO 7-1 standardına uygundur.

THREADS Threads for Clamp Saddles are compatible with ISO 7-1 standard.

SU KALİTESİ ÜZERİNDEKİ ETKİSİ Ekleme parçaları, içme suyu üzerinde mikroorganizmaların çoğalmalarına izin vermemelidir. KIWA ve TSE kuruluşlarının laboratuvarları tarafından ilgili testler yapılarak raporlandırılmıştır.

INFLUENCE ON WATER QUALITY Compression Fittings must not allow increasing microorganism on drinking water. It is reported with the related tests by the laboratories of KIWA and TSE Institutions.

Because the nuts are inserted in their housing on the lower part, it provides quick and easy installation.



Somunlar, alt kapaktaki yuvalarına yerleştirildiği için hızlı ve kolay montaj yapılmasını sağlar.

SERTİFİKALARIMIZ / CERTIFICATES



MARKA TESCİL BELGESİ
BRAND REGISTRATION



KALİTE YÖNETİM BELGESİ
QUALITY MANAGEMENT
SYSTEM CERTIFICATE



ÇEVRE YÖNETİM BELGESİ
ENVIRONMENT MANAGEMENT
SYSTEM CERTIFICATE



İŞ SAĞLIĞI GÜVENLİĞİ
OCCUPATIONAL HEALTH &
SAFETY MANAGEMENT SYSTEM
CERTIFICATE



**YENİ MAVİ SERİ
AMERİKA PATENTİ**
NEW BLUE SERIES
USA DESIGN PATENT



KIWA BELGESİ
KIWA CERTIFICATE



**TSE COVID-19
GÜVENLİ ÜRETİM BELGESİ**
TSE COVID-19
SAFE PRODUCTION CERTIFICATE



**MAVİ SERİ
TASARIM TESCİL BELGESİ**
BLUE SERIES - DESIGN
REGISTRATION CERTIFICATE



**YENİ MAVİ SERİ
TASARIM TESCİL**
NEW BLUE SERIES - DESIGN
REGISTRATION CERTIFICATE



**YENİ PRİZ KOLYE
TASARIM TESCİL**
NEW CLAMP SADDLE
DESIGN REGISTRATION
CERTIFICATE



**YENİ YEŞİL SERİ
TASARIM TESCİL**
NEW GREEN SERIES - DESIGN
REGISTRATION CERTIFICATE

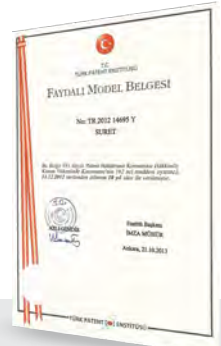

**ESNEK BORU TUTUCULAR
FAYDALI MODEL BELGESİ**
UTILITY MODEL CERTIFICATE
FLEXIBLE O-RING HOLDERS



**TS ISO 17885 TÜRK
STANDARTLARINA UYGUNLUK**
TSE ISO 17885 Certificate Of
Conformity to TSE



**TS ISO 13460-1 TÜRK
STANDARTLARINA UYGUNLUK**
TSE ISO 13460-1 Certificate
Of Conformity to TSE



**TS ISO 9911 VANALAR TSE
KRİTERLERİNE UYGUNLUK**
TS ISO 9911 Valves Certificate
Of Conformity to TSE



**TS ISO 9261 TÜRK
STANDARTLARINA UYGUNLUK**
TS ISO 9261 Certificate
Of Conformity to TSE



**TS 13716 VANA KUTULARI TÜRK
STANDARTLARINA UYGUNLUK**
TS 13716 Valve Boxes Certificate
Of Conformity to TSE

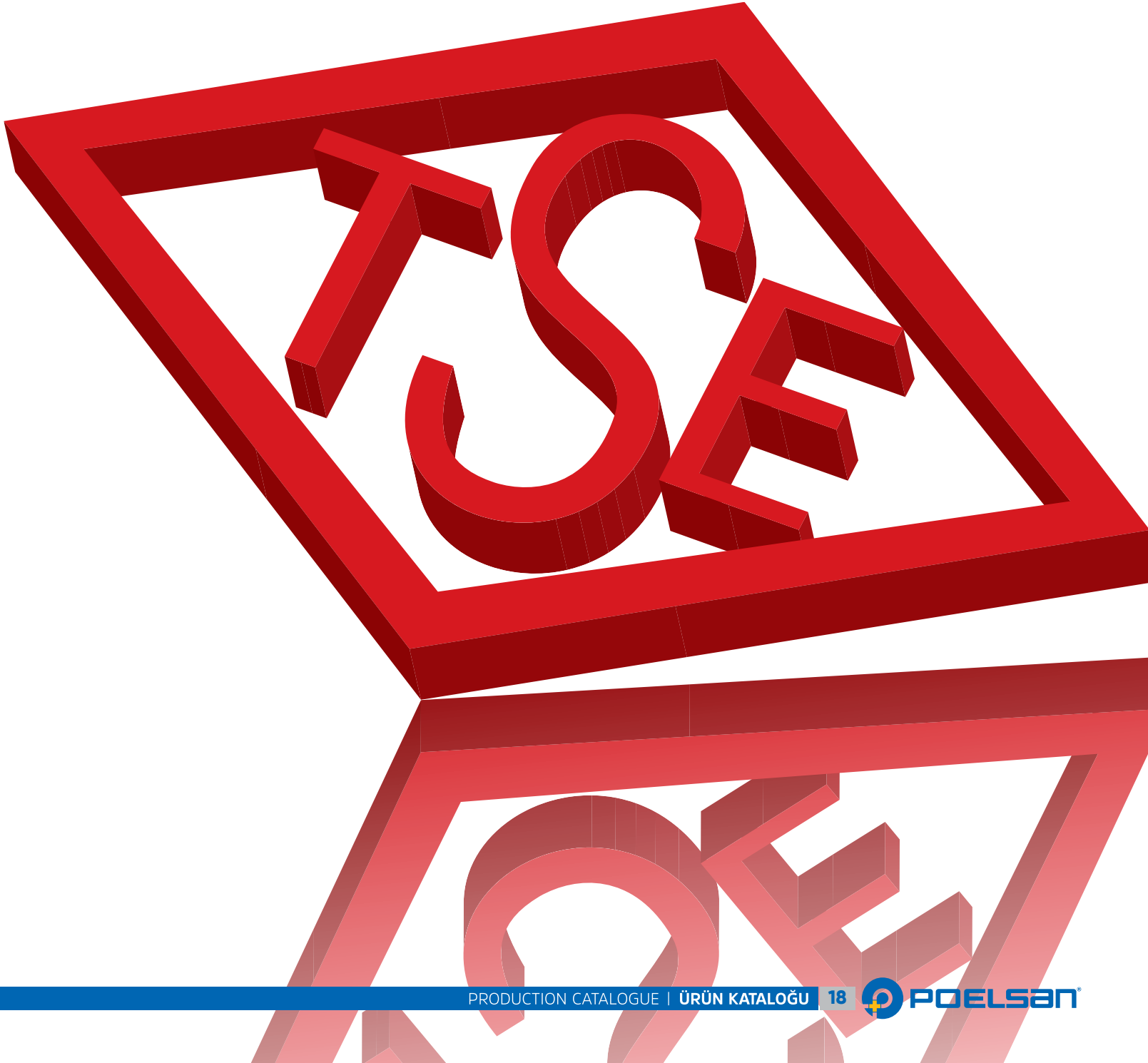

AMBALAJ BİLGİLERİMİZ / PACKAGE INFORMATION



Koli Kullanılan Ürün Grupları

Mavi Seri
Yeşil Seri
Priz Kolye Geçmeli
Layflat Ek Parçaları & Çıkış Nipelleri
Dişli Bağlantı Elemanları
Mini Vanalar (DN 8)
Mini Vanalar (DN 15)
Damla Sulama Kurtağzı Ek Parçaları
Yassı Damla Sulama Ek Parçaları
Yüzüklü Yassı Damla Sulama Ek Parçaları
Minisprinkler & Mikrofittingler
Hat Üstü Damlatıcılar
Priz Kolye
Manyetik Lokma Ucu
(16080, 16083)
Yeşil Seri Küresel Vana
Mavi Seri Küresel Vana
Boru Delme Aparatı
(16096, 16098, 16092, 16094)

Product Series in Box

Blue Series
Green Series
Clamp Saddles With Slide
Layflat Fittings & Offtake Nipples
Threaded Fittings
Mini Valves (DN 8)
Mini Valves (DN 15)
Dripline Barbed Fittings
Drip Tape Fittings
Drip Tape Fittings With Ring
Minisprinklers & Microfittings
On-Line Drippers
Clamp Saddles
Magnetic Socket Wrench
(16080, 16083)
Green Series Ball Valves
Blue Series Ball Valves
Driller
(16096, 16098, 16092, 16094)

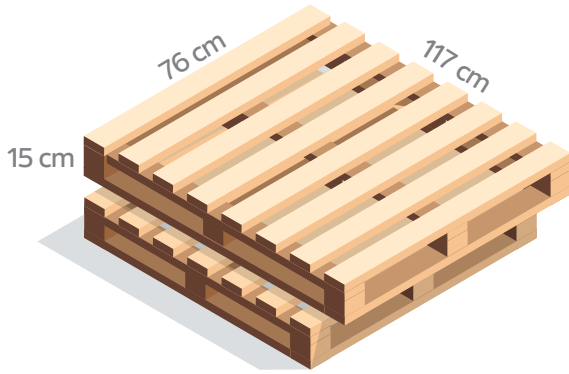

Palet Kullanılan Ürün Grupları

Vana Kutuları

Product Series in The Pallet

Valve Boxes



Çuval Kullanılan Ürün Grupları

+ Küresel Vanalar hariç tüm ürünlerimizde çuval kullanılmaktadır.

NOTLAR / NOTES

Blank area for notes, consisting of 20 horizontal grey lines.



01/2021

Şabanoğlu OSB Mahallesi Ulubatlı Caddesi No: 6 Tekkeköy SAMSUN TÜRKİYE
Tel: +90 362 266 75 24 Faks: +90 362 266 77 51 GSM: +90 544 366 69 64

www.poelsan.com @ poelsan in poelsan f | poelsanplastik poelsan@poelsan.com